

REV	ZONE	ECN	REVISION DESCRIPTION	DATE	ENG
F	...	...	Redrawn in Solidworks	3/22	NA

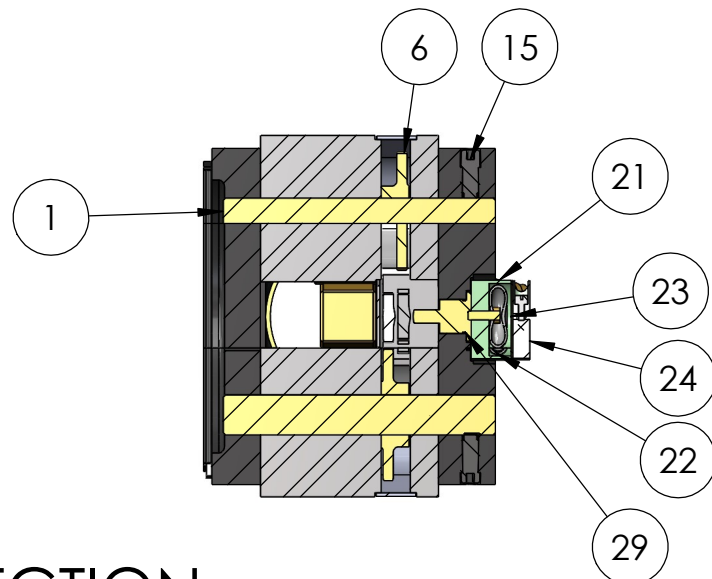

SECTION A-A

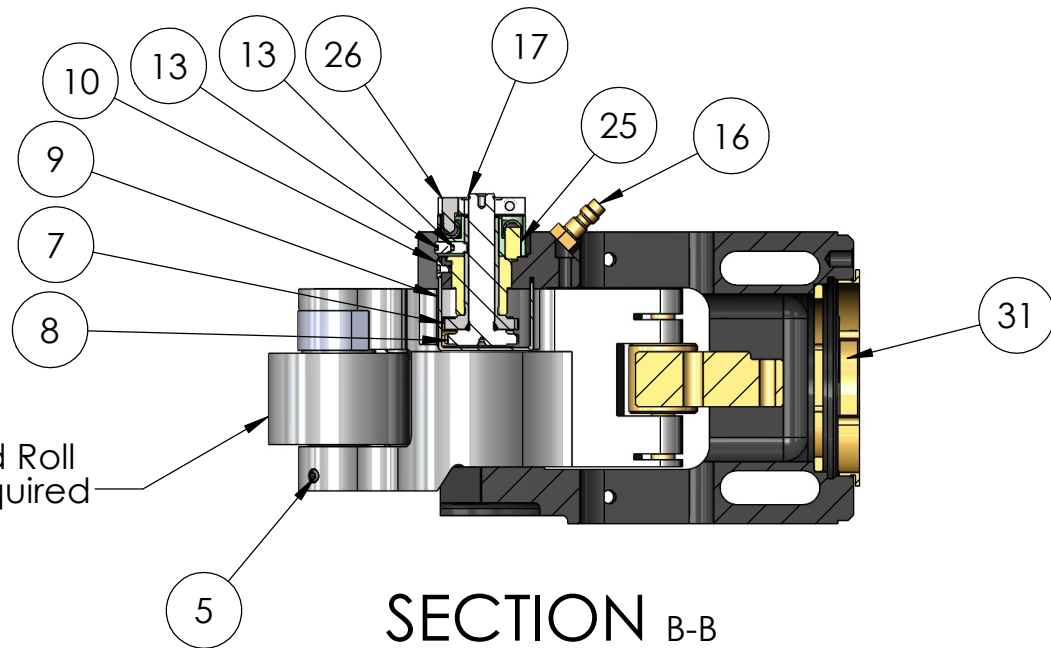
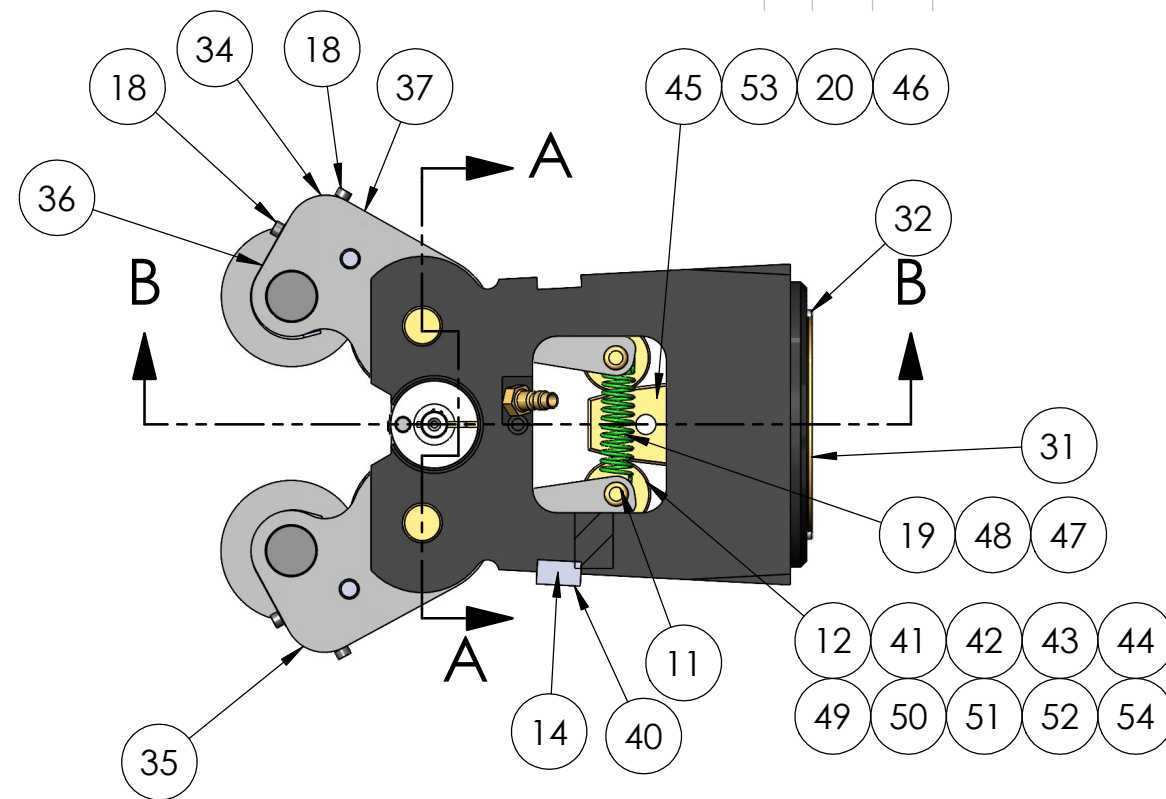

SECTION B-B

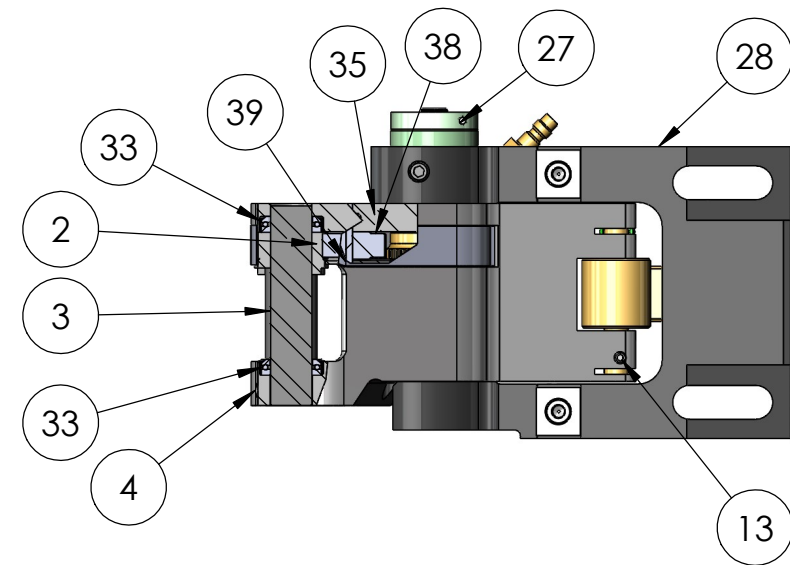

THIS DRAWING IS THE CONFIDENTIAL AND EXCLUSIVE PROPERTY OF C.J. WINTER MACHINE TECHNOLOGIES, INC. AND MAY NOT BE COPIED, REPRODUCED, OR DISCLOSED IN ANY WAY, WHATSOEVER TO ANYONE WITHOUT THE EXPRESS WRITTEN PERMISSION OF C.J. WINTER MACHINE TECHNOLOGIES, INC. UNLAWFUL DISCLOSURE MAY RESULT IN PROSECUTION © 2004 C.J. WINTER MACHINE TECHNOLOGIES, INC.

UNLESS OTHERWISE SPECIFIED: DRAWING MUST COMPLY TO C. J. WINTER ENGINEERING STANDARD E-1058 & ASME Y14.5M 1994. UNTOLERANCED DIMENSIONS ARE BASIC  
 .020 A B C SW

DRAWN BY:  
 DWG DATE:  
 ENG. APPR:  
 APPR DATE:  
 MATERIAL:  
 HEAT TRT:



172913: Bracket Assembly

DWG SIZE SCALE: 1:3  
**B** Sheet1  
 DRAWING NO.  
**172SA1**

