

REV	ZONE	ECN	REVISION DESCRIPTION	DATE	ENG
F	Redrawn in Solidworks	2/22	NA

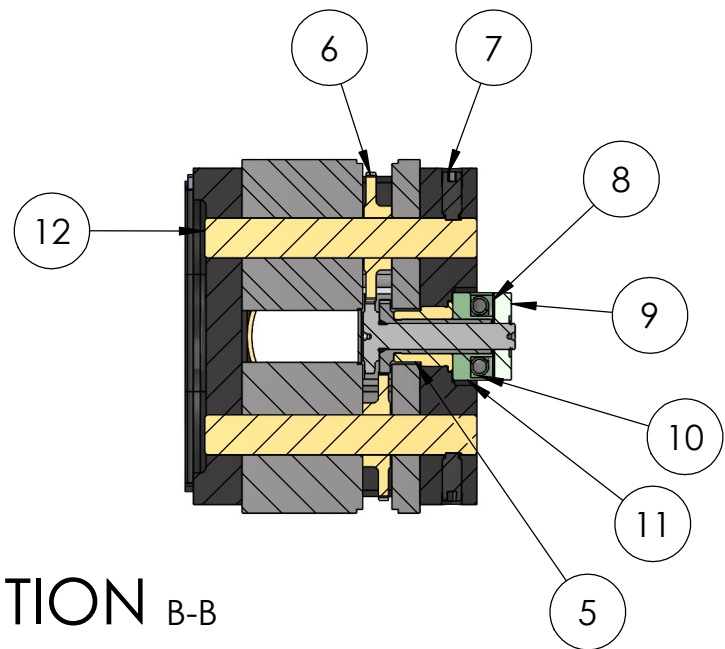

SECTION B-B

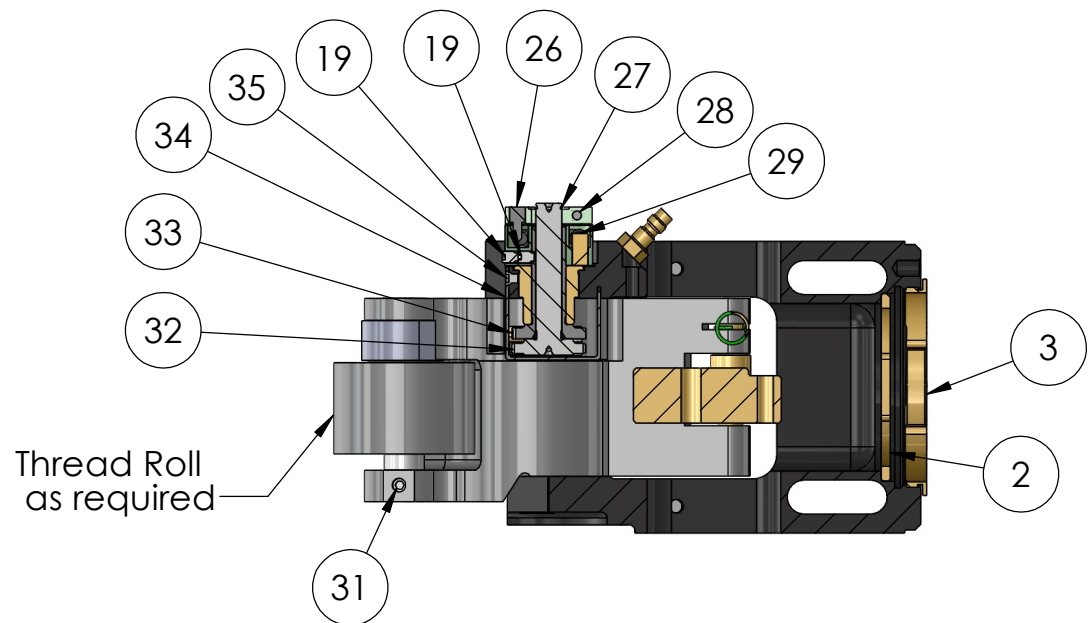
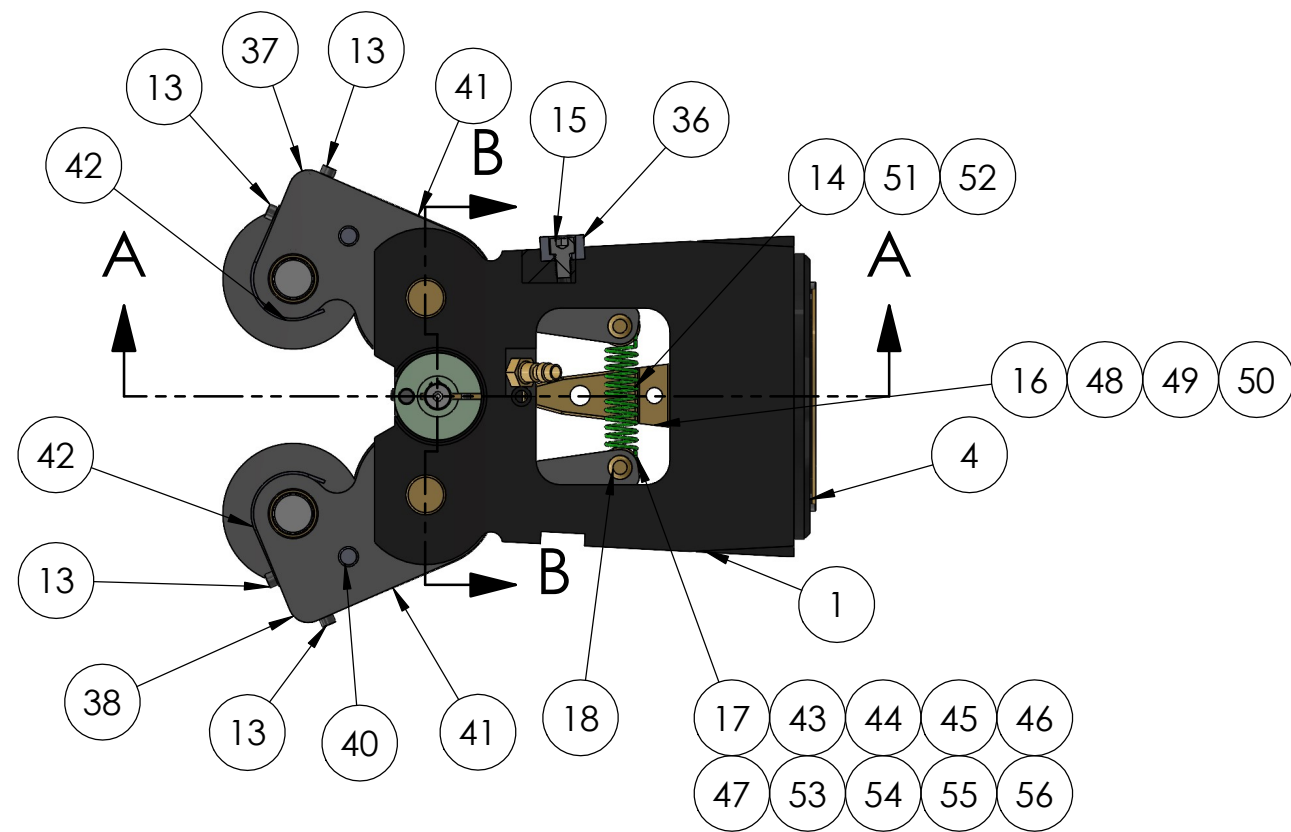

SECTION A-A

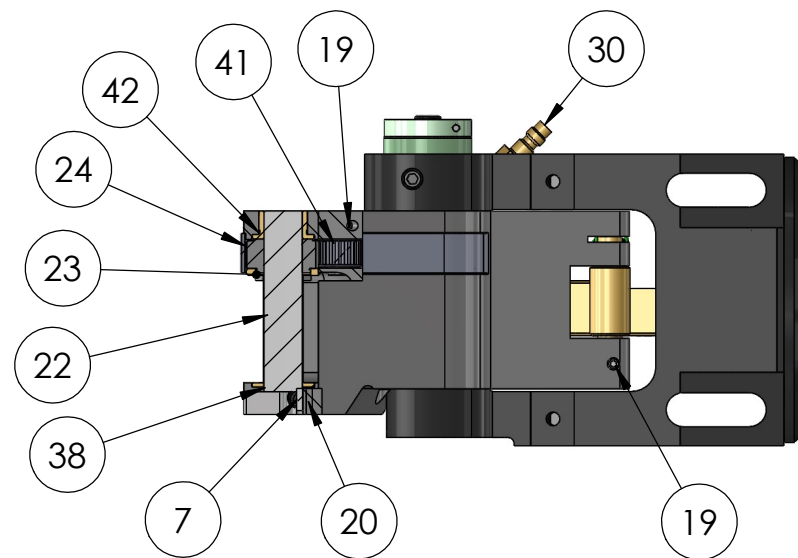

THIS DRAWING IS THE CONFIDENTIAL AND EXCLUSIVE PROPERTY OF C.J. WINTER MACHINE TECHNOLOGIES, INC. AND MAY NOT BE COPIED, REPRODUCED, OR DISCLOSED IN ANY WAY, WHATSOEVER TO ANYONE WITHOUT THE EXPRESS WRITTEN PERMISSION OF C.J. WINTER MACHINE TECHNOLOGIES, INC. UNLAWFUL DISCLOSURE MAY RESULT IN PROSECUTION © 2004 C.J. WINTER MACHINE TECHNOLOGIES, INC.

UNLESS OTHERWISE SPECIFIED: DRAWING MUST COMPLY TO C. J. WINTER ENGINEERING STANDARD E1058 & ASME Y14.5M 1994. UNTOLERANCED DIMENSIONS ARE BASIC
 .020 A B C SW

DRAWN BY:
 DWG DATE:
 ENG. APPR:
 APPR DATE:
 MATERIAL:
 HEAT TRT:



170904: Bracket Assembly

DWG SIZE SCALE: 1:3
B Sheet1
 DRAWING NO.
170SA1

6				5				4				3				2				1			
ITEM NO.	PART NO.	DESCRIPTION	QTY.	ITEM NO.	PART NO.	DESCRIPTION	QTY.	ITEM NO.	PART NO.	DESCRIPTION	QTY.	ITEM NO.	PART NO.	DESCRIPTION	QTY.	ITEM NO.	PART NO.	DESCRIPTION	QTY.				
1	160071QR	Quick Release Roll Arm Bracket (SA1)	1	28	141379	Screw: SHCS, #6-32 x .500	1	29	160053	Pin: Dowel, .250 Dia. x .500	1	30	125070	Quick Disconnect Plug	1	31	140280	Screw: SSS, 1/4-28 x .250 Half Dog	2				
2	160417	Quick Release Washer	1	32	160093	Internal Gear	1	33	160004	External Gear	1	34	160085	Center Gear Guard	1	35	160086	Screw: FHSS, #6-32 x .188	1				
3	160416	Quick Release Adapter	1	36	160072	Key	2	37	170003	R.H. Roll Arm	1	38	170004	L.H. Roll Arm	1	39	170013	Intermediate Idler Gear	2				
4	838-19	Pin: Spring, .188 dia x .500	2	40	170014	Intermediate Idler Pin	2	41	170015	Idler Gear Guard	2	42	170016	Roll Gear Guard	2	43	160007	Wedge Roller (1.075 Dia)	2				
5	160048	Compensator Bushing	1	44	160026	Wedge Roller (.750 Dia)	2	45	160027	Wedge Roller (.875 Dia)	2	46	160028	Wedge Roller (1.000 Dia)	2	47	160029	Wedge Roller (1.312 Dia)	2				
6	160005	Idler Gear	2	48	160031	Wedge, Medium	1	49	160032	Wedge, Large	1	50	160033	Wedge, Ex-Large	1	51	160034	Roll Arm Spring, Red	1				
7	160103	Screw: SSS, 5/16-18 x .750 Half Dog Pt.	4	52	160130	Roll Arm Spring, Yellow	1	53	160402	Wedge Roller (.688 Dia.)	2	54	160403	Wedge Roller (.813 dia.)	2	55	160405	Wedge Roller (.938 dia.)	2				
8	160102	Cover Plate	1	56	160406	Wedge Roller (1.156 Dia.)	2	20	160099	Pin: Dowel, .094 dia. x .438	2	21	160098	Roll Arm Thrust Washer	2	22	160044	Carbide Roll Pin	2				
9	160092	Adjusting Collar	1					23	160043	Roll Gear Washer	2	24	160006	Roll Gear	2	25	160097	Roll Arm Thrust Bushing	2				
10	160051	Compensator Spring	2					26	160052	Adjusting Collar Pin	1	27	160108	Retainer Ring, Bowed: .394 Dia	1								
11	160050	Spring Retainer	1																				
12	160145	Fulcrum Pin (New Style)	2																				
13	140207	Screw: SHCS, #6-32 x .250	4																				
14	160035	Roll Arm Spring, Green	1																				
15	140204	Screw: SHCS, 1/4-28 x .375	2																				
16	160030	Wedge, Narrow	1																				
17	160025	Wedge Roller (.625 Dia)	2																				
18	160091	Wedge Roller Pin	2																				

REV	ZONE	ECN	REVISION DESCRIPTION	DATE	ENG
F	Redrawn in Solidworks	2/22	NA

Components
170904: Bracket Assembly-shown here
160911QR: Power Pack Assembly-not shown
141600: Control Valve Assembly- not shown
Serial No. Range
170196-Current

A

A

THIS DRAWING IS THE CONFIDENTIAL AND EXCLUSIVE PROPERTY OF C.J. WINTER MACHINE TECHNOLOGIES, INC. AND MAY NOT BE COPIED, REPRODUCED, OR DISCLOSED IN ANY WAY, WHATSOEVER, TO ANYONE WITHOUT THE EXPRESS WRITTEN PERMISSION OF C.J. WINTER MACHINE TECHNOLOGIES, INC. UNLAWFUL DISCLOSURE MAY RESULT IN PROSECUTION. © 2004 C.J. WINTER MACHINE TECHNOLOGIES, INC.	UNLESS OTHERWISE SPECIFIED: DRAWING MUST COMPLY TO C. J. WINTER ENGINEERING STANDARD E1058 & ASME Y14.5M 1994. UNTOLERANCED DIMENSIONS ARE BASIC 	DRAWN BY: DWG DATE:		DWG SIZE: SCALE: 1:3 B BOM
		ENG. APPR: APPR DATE:		DRAWING NO. 170SA1
		MATERIAL: HEAT TRT:	170904: Bracket Assembly	