

REV	ZONE	ECN	REVISION DESCRIPTION	DATE	ENG
E	Redrawn in Solidworks	2/22	NA

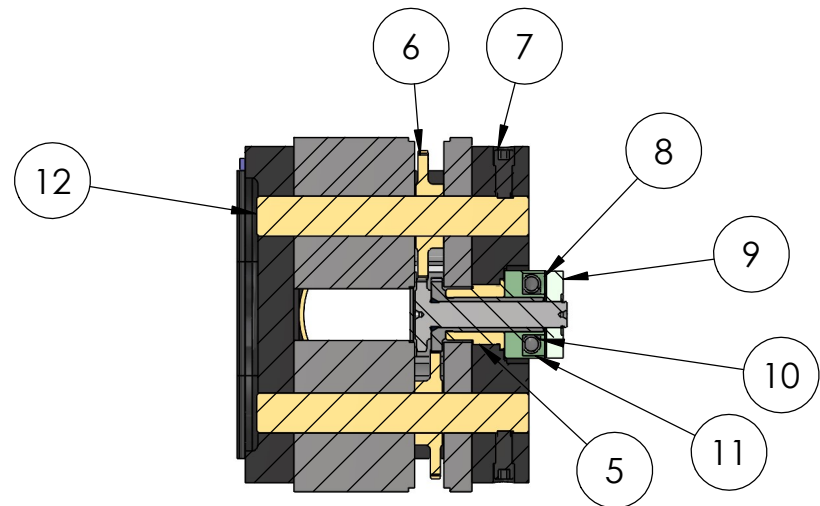

SECTION B-B

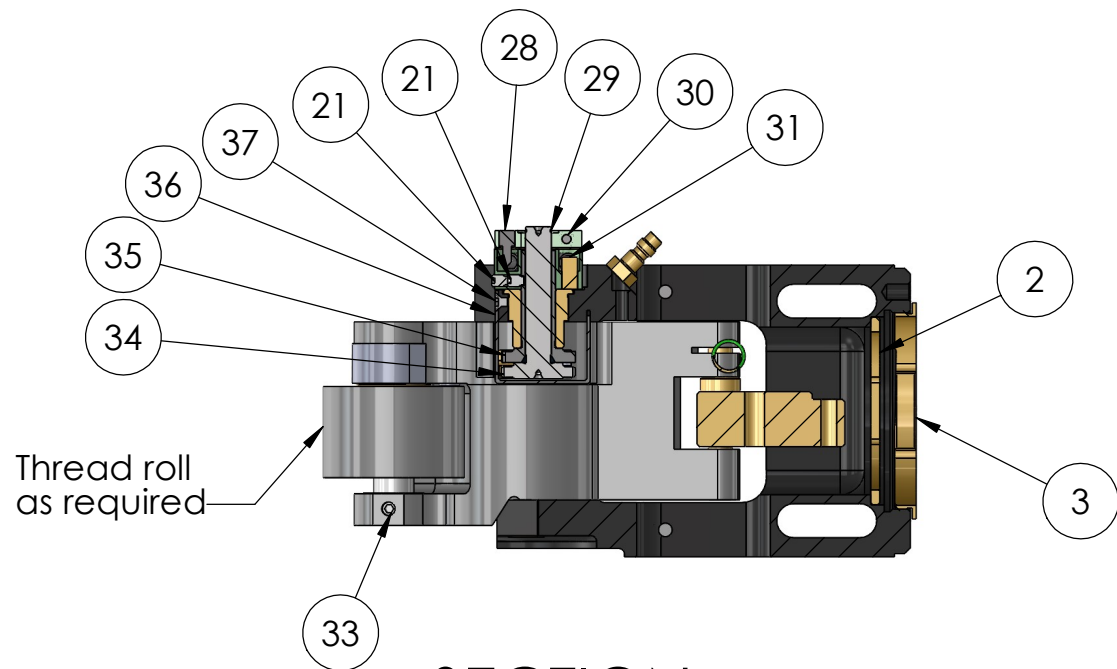
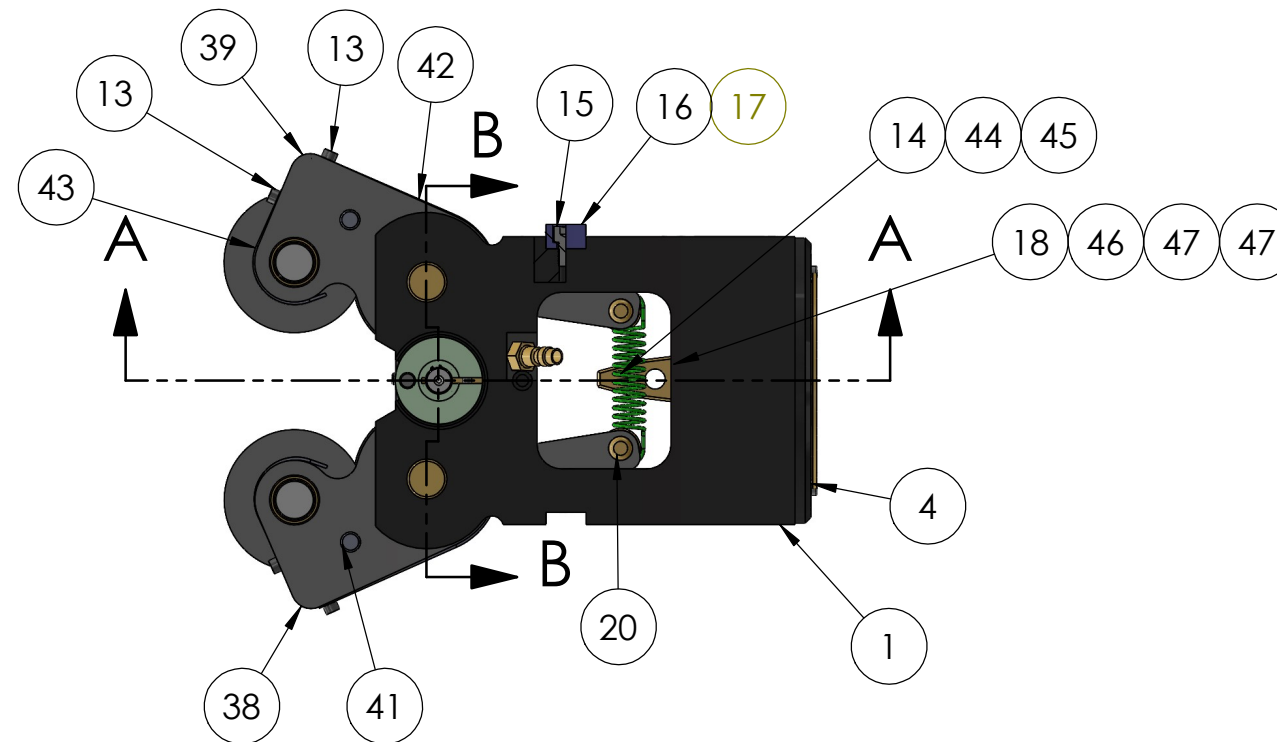

SECTION A-A

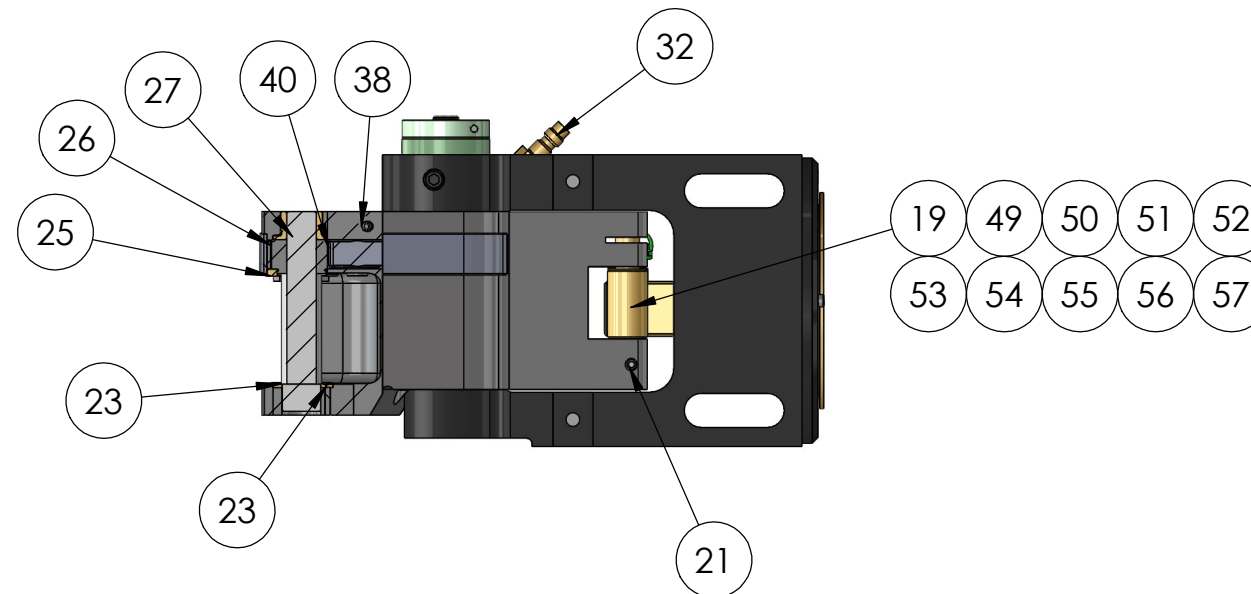

THIS DRAWING IS THE CONFIDENTIAL AND EXCLUSIVE PROPERTY OF C.J. WINTER MACHINE TECHNOLOGIES, INC. AND MAY NOT BE COPIED, REPRODUCED, OR DISCLOSED IN ANY WAY, WHATSOEVER TO ANYONE WITHOUT THE EXPRESS WRITTEN PERMISSION OF C.J. WINTER MACHINE TECHNOLOGIES, INC. UNLAWFUL DISCLOSURE MAY RESULT IN PROSECUTION © 2004 C.J. WINTER MACHINE TECHNOLOGIES, INC.

UNLESS OTHERWISE SPECIFIED: DRAWING MUST COMPLY TO C. J. WINTER ENGINEERING STANDARD E-1058 & ASME Y14.5M 1994. UNTOLERANCED DIMENSIONS ARE BASIC
 .020 A B C SW

DRAWN BY:
 DWG DATE:
 ENG. APPR:
 APPR DATE:
 MATERIAL:
 HEAT TRT:



170903 Bracket Assembly

DWG SIZE SCALE: 1:3
B Sheet1
 DRAWING NO.
170SA

6				5				4				3			
ITEM NO.	PART NO.	DESCRIPTION	QTY.	ITEM NO.	PART NO.	DESCRIPTION	QTY.	ITEM NO.	PART NO.	DESCRIPTION	QTY.	ITEM NO.	PART NO.	DESCRIPTION	QTY.
1	160001QR	Quick Release Roll Arm Bracket (SA)	1	28	160052	Adjusting Collar Pin	1								
2	160417	Quick Release Washer	1	29	160108	Retainer Ring, Bowed: .394 Dia	1								
3	160416	Quick Release Adapter	1	30	141379	Screw: SHCS, #6-32 x .500	1								
4	838-19	Pin: Spring, .188 dia x .500	2	31	160053	Pin: Dowel, .250 Dia. x .500	1								
5	160048	Compensator Bushing	1	32	125070	Quick Disconnect Plug	1								
6	160005	Idler Gear	2	33	140280	Screw: SSS, 1/4-28 x .250 Half Dog	2								
7	160103	Screw: SSS, 5/16-18 x .750 Half Dog Pt.	4	34	160093	Internal Gear	1								
8	160102	Cover Plate	1	35	160004	External Gear	1								
9	160092	Adjusting Collar	1	36	160085	Center Gear Guard	1								
10	160051	Compensator Spring	2	37	160086	Screw: FHSS, #6-32 x .188	1								
11	160050	Spring Retainer	1	38	170004	L.H. Roll Arm	1								
12	160145	Fulcrum Pin (New Style)	2	39	170003	R.H. Roll Arm	1								
13	140207	Screw: SHCS, #6-32 x .250	4	40	170013	Intermediate Idler Gear	2								
14	160035	Roll Arm Spring, Green	1	41	170014	Intermediate Idler Pin	2								
15	140204	Screw: SHCS, 1/4-28 x .375	2	42	170015	Idler Gear Guard	2								
16	160039	Key	2	43	170016	Roll Gear Guard	2								
17	160040	Stepped Key (.750)	2	44	160034	Roll Arm Spring, Red	1								
18	160030	Wedge, Narrow	1	45	160130	Roll Arm Spring, Yellow	1								
19	160025	Wedge Roller (.625 Dia)	2	46	160031	Wedge, Medium	1								
20	160091	Wedge Roller Pin	2	47	160033	Wedge, Ex-Large	1								
21	160054	Screw: SSS, #10-32 x .250 Half Dog Pt.	6	48	160032	Wedge, Large	1								
22	160099	Pin: Dowel, .094 dia. x .438	2	49	160007	Wedge Roller (1.075 Dia)	2								
23	160098	Roll Arm Thrust Washer	2	50	160026	Wedge Roller (.750 Dia)	2								
24	160044	Carbide Roll Pin	2	51	160027	Wedge Roller (.875 Dia)	2								
25	160043	Roll Gear Washer	2	52	160028	Wedge Roller (1.000 Dia)	2								
26	160006	Roll Gear	2	53	160029	Wedge Roller (1.312 Dia)	2								
27	160097	Roll Arm Thrust Bushing	2	54	160402	Wedge Roller (.688 Dia.)	2								
				55	160403	Wedge Roller (.813 dia.)	2								
				56	160405	Wedge Roller (.938 dia.)	2								
				57	160406	Wedge Roller (1.156 Dia.)	2								

REV	ZONE	ECN	REVISION DESCRIPTION	DATE	ENG
E	Redrawn in Solidworks	2/22	NA

Components
170903: Bracket Assembly-shown here
160911QR: Power Pack Assembly-not shown
141600: Control Valve Assembly- not shown
Serial No. Range
170196-Current

THIS DRAWING IS THE CONFIDENTIAL AND EXCLUSIVE PROPERTY OF C.J. WINTER MACHINE TECHNOLOGIES, INC. AND MAY NOT BE COPIED, REPRODUCED, OR DISCLOSED IN ANY WAY, WHATSOEVER TO ANYONE WITHOUT THE EXPRESS WRITTEN PERMISSION OF C.J. WINTER MACHINE TECHNOLOGIES, INC. UNLAWFUL DISCLOSURE MAY RESULT IN PROSECUTION © 2004 C.J. WINTER MACHINE TECHNOLOGIES, INC.

UNLESS OTHERWISE SPECIFIED: DRAWING MUST COMPLY TO C. J. WINTER ENGINEERING STANDARD E1058 & ASME Y14.5M 1994. UNTOLERANCED DIMENSIONS ARE BASIC

 .020 A B C SW

DRAWN BY:
 DWG DATE:
 ENG. APPR:
 APPR DATE:
 MATERIAL:
 HEAT TRT:

	C. J. WINTER MACHINE TECHNOLOGIES, INC.	DWG SIZE	SCALE: 1:3
		B	BOM
170903 Bracket Assembly		DRAWING NO. 170SA	

D

D

C

C

B

B

A

A

6

5

4

3

2

1