

REV	ZONE	ECN	REVISION DESCRIPTION	DATE	ENG
D	Redrawn in Solidworks	3/22	NA

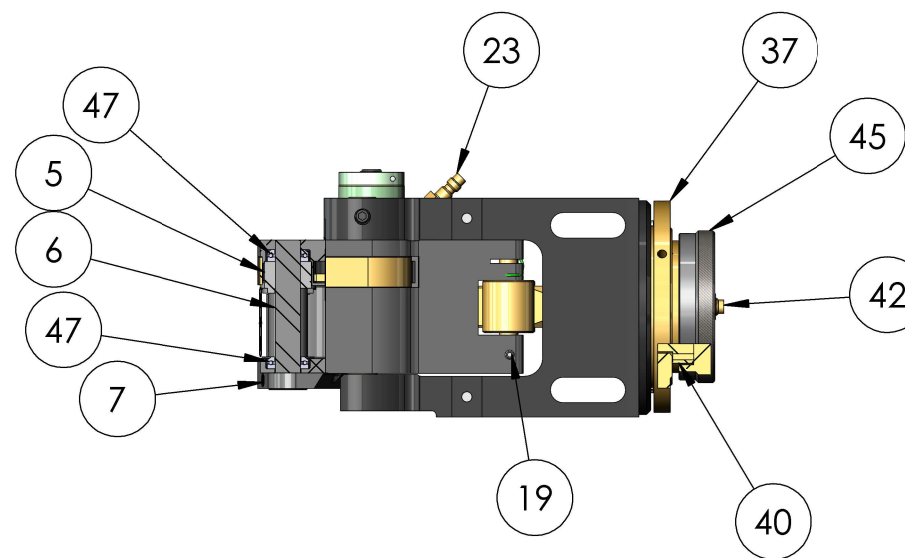
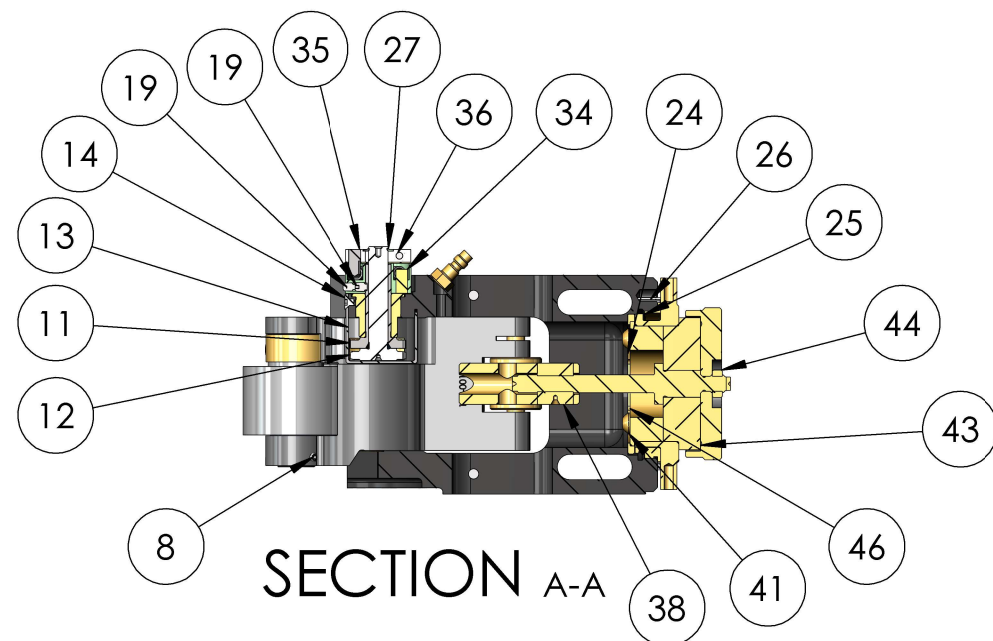
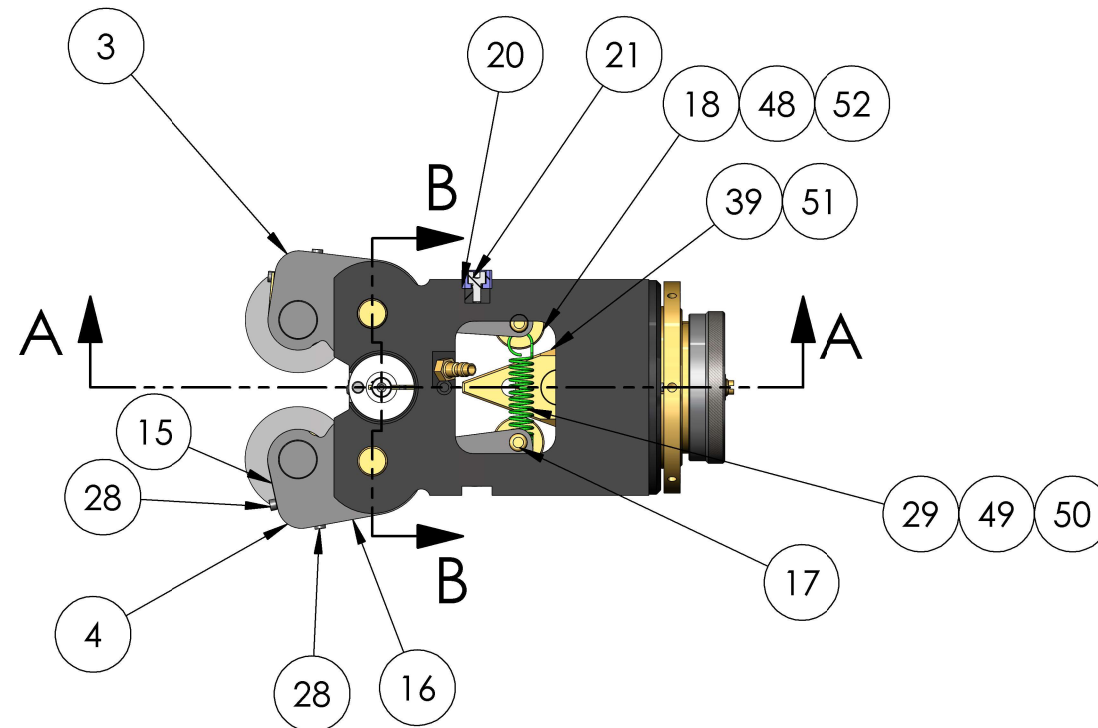
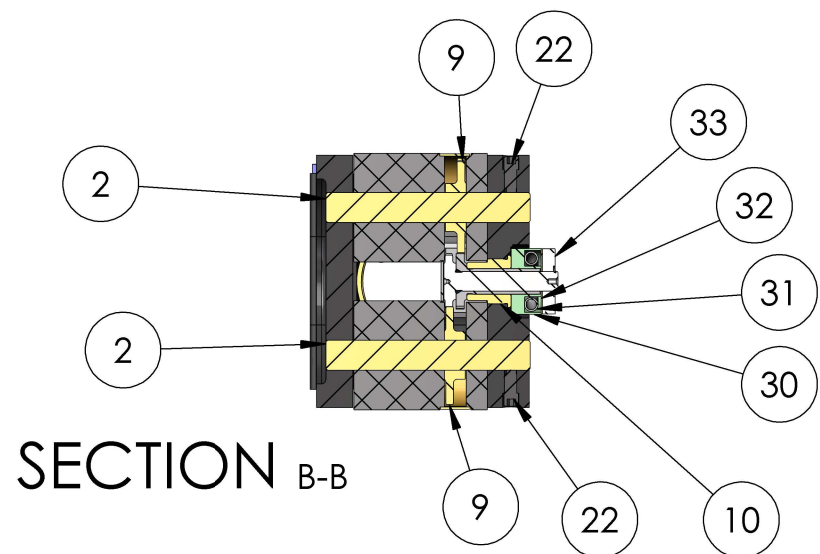

THIS DRAWING IS THE CONFIDENTIAL AND EXCLUSIVE PROPERTY OF C.J. WINTER MACHINE TECHNOLOGIES, INC. AND MAY NOT BE COPIED, REPRODUCED, OR DISCLOSED IN ANY WAY, WHATSOEVER TO ANYONE WITHOUT THE EXPRESS WRITTEN PERMISSION OF C.J. WINTER MACHINE TECHNOLOGIES, INC. UNLAWFUL DISCLOSURE MAY RESULT IN PROSECUTION © 2004 C.J. WINTER MACHINE TECHNOLOGIES, INC.

UNLESS OTHERWISE SPECIFIED: DRAWING MUST COMPLY TO C. J. WINTER ENGINEERING STANDARD E1058 & ASME Y14.5M 1994. UNTOLERANCED DIMENSIONS ARE BASIC

.020
 A
 B
 C
 SW

DRAWN BY:EA
 DWG DATE:4/5/2024
 ENG. APPR:
 APPR DATE:
 MATERIAL:
 HEAT TRT:



162912T: Tangential Attachment

DWG SIZE: B
 SCALE: 1:4
 Sheet1

DRAWING NO. 162SAT

