

REV	ZONE	ECN	REVISION DESCRIPTION	DATE	ENG
F	Redrawn in SolidWorks	2/22	NA

SECTION B-B

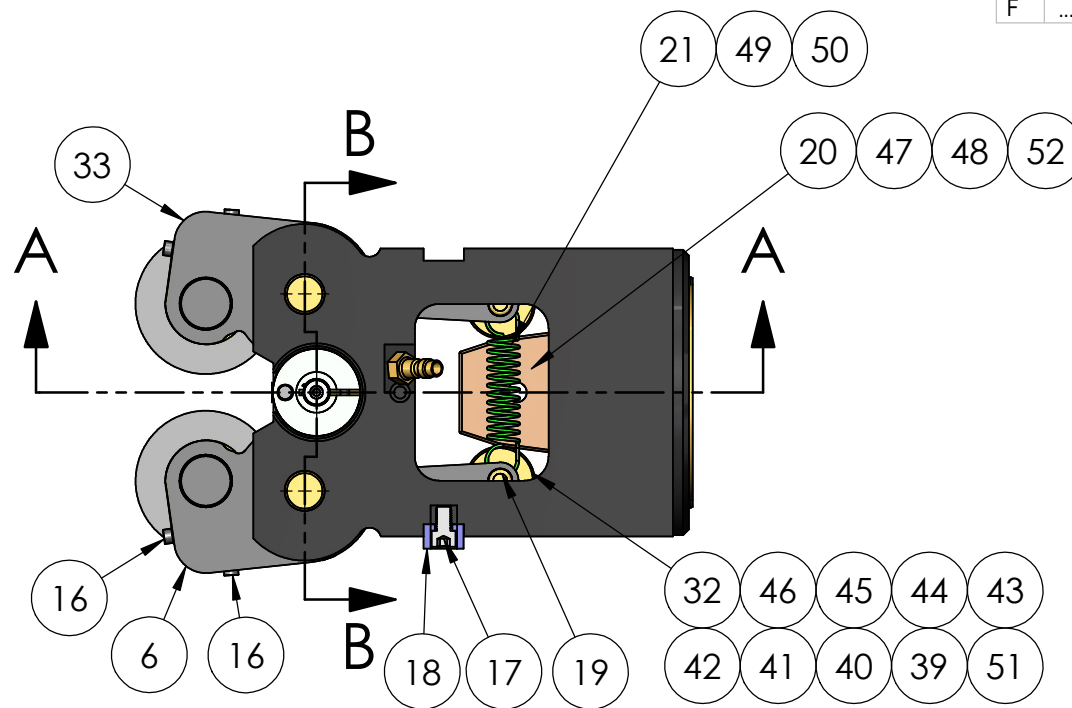

SECTION A-A

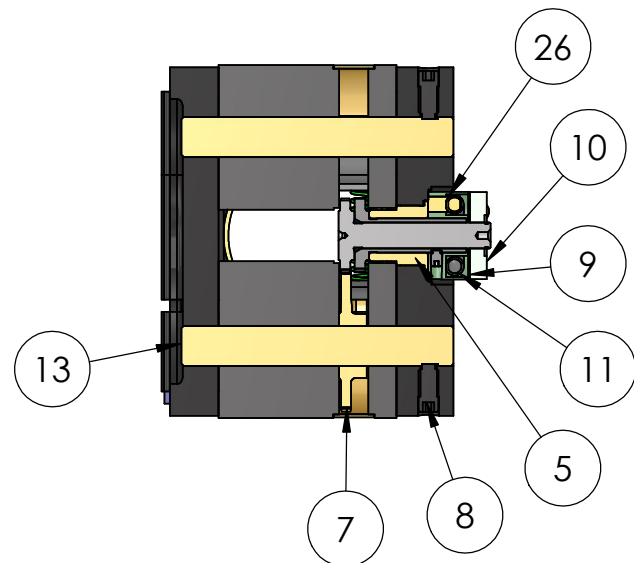
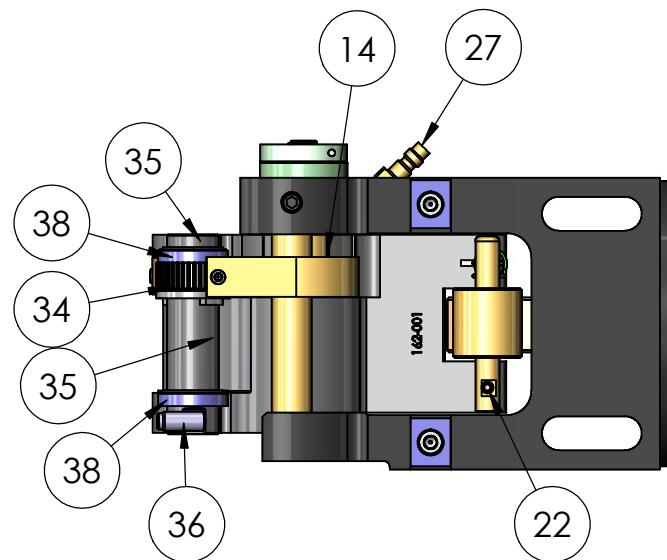
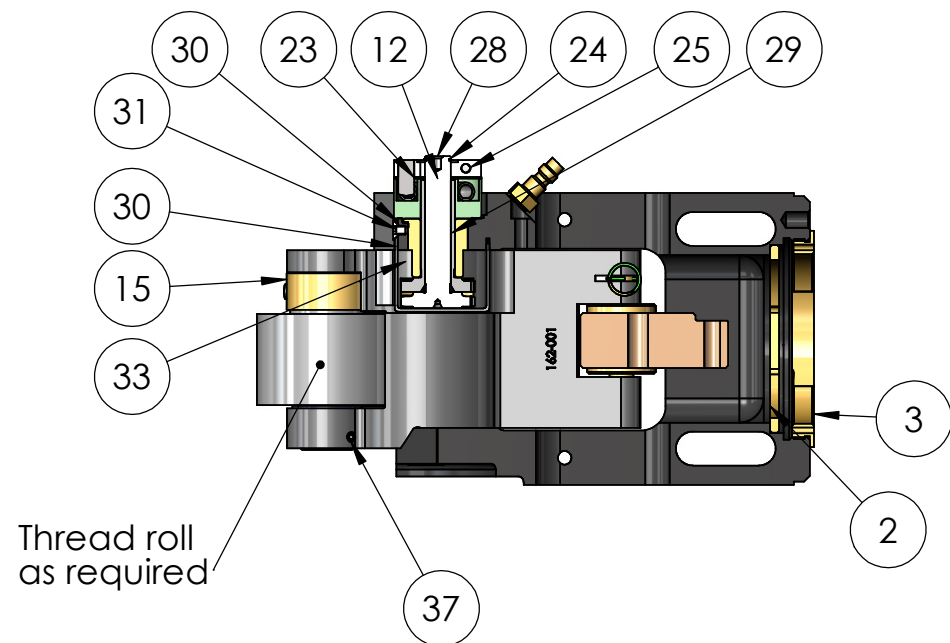

View shown without L.H roll arm

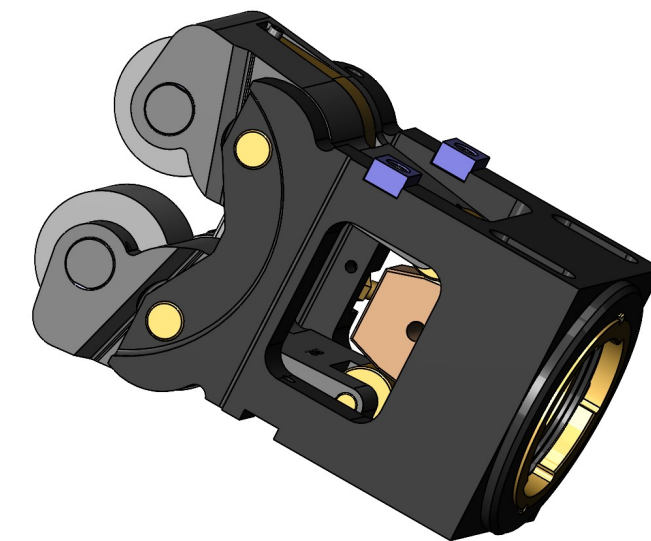

THIS DRAWING IS THE CONFIDENTIAL AND EXCLUSIVE PROPERTY OF C.J. WINTER MACHINE TECHNOLOGIES, INC. AND MAY NOT BE COPIED, REPRODUCED, OR DISCLOSED IN ANY WAY, WHATSOEVER TO ANYONE WITHOUT THE EXPRESS WRITTEN PERMISSION OF C.J. WINTER MACHINE TECHNOLOGIES, INC. UNLAWFUL DISCLOSURE MAY RESULT IN PROSECUTION © 2004 C.J. WINTER MACHINE TECHNOLOGIES, INC.

UNLESS OTHERWISE SPECIFIED: DRAWING MUST COMPLY TO C. J. WINTER ENGINEERING STANDARD E1058 & ASME Y14.5M 1994. UNTOLERANCED DIMENSIONS ARE BASIC
 .020 A B C SW

DRAWN BY: N. Albornoz
 DWG DATE: 2/8/22
 ENG. APPR: P. Allart
 APPR DATE: 2/8/22
 MATERIAL:
 HEAT TRT:



162912: Bracket Assembly

DWG SIZE SCALE: 1:3
B Sheet1
 DRAWING NO.
162SA

6				5				4				3				2				1					
ITEM NO.	PART NO.	DESCRIPTION	QTY.	ITEM NO.	PART NO.	DESCRIPTION	QTY.	ITEM NO.	PART NO.	DESCRIPTION	QTY.	ITEM NO.	PART NO.	DESCRIPTION	QTY.	ITEM NO.	PART NO.	DESCRIPTION	QTY.	REV	ZONE	ECN	REVISION DESCRIPTION	DATE	ENG
																				F	Redrawn in Solidworks	2/22	NA
1	160001QR	Quick Release Roll Arm Bracket (SA)	1	31	160086	Screw: FHSS, #6-32 x .188	1																		
2	160417	Quick Release Washer	1	32	160007	Wedge Roller (1.075 Dia)	2																		
3	160416	Quick Release Adapter	1	33	162001	R.H. Roll Arm	1																		
4	838-19	Pin: Spring, .188 Dia x .500	2	34	162020	Roll Gear	2																		
5	160048	Compensator Bushing	1	35	162007	Carbide Roll Pin	2																		
6	162002	L.H. Roll Arm	1	36	162003	Adjusting Screw	2																		
7	160005	Idler Gear	2	37	162008	Screw: SSS, #10-32 x .375 Half dog Pt.	2																		
8	160103	Screw: SSS, 5/16-18 x .750 Half Dog Pt.	2	38	162004	Thrust Bearing	4																		
9	160102	Cover Plate	1	39	160406	Wedge Roller (1.156 Dia.)	2																		
10	160092	Adjusting Collar	1	40	160405	Wedge Roller (.938 dia.)	2																		
11	160051	Compensator Spring	2	41	160403	Wedge Roller (.813 dia.)	2																		
12	160050	Spring Retainer	1	42	160402	Wedge Roller (.688 Dia.)	2																		
13	160145	Fulcrum Pin (New Style)	2	43	160029	Wedge Roller (1.312 Dia)	2																		
14	160046	Idler Gear Guard	2	44	160028	Wedge Roller (1.000 Dia)	2																		
15	160045	Roll Gear Guard	2	45	160027	Wedge Roller (.875 Dia)	2																		
16	140207	Screw: SHCS, #6-32 x .250	4	46	160026	Wedge Roller (.750 Dia)	2																		
17	140204	Screw: SHCS, 1/4-28 x .375	2	47	160031	Wedge, Medium	1																		
18	160039	Key	2	48	160033	Wedge, Ex-Large	1																		
19	160091	Wedge Roller Pin	2	49	160034	Roll Arm Spring, Red	1																		
20	160032	Wedge, Large	2	50	160130	Roll Arm Spring, Yellow	1																		
21	160035	Roll Arm Spring, Green	1	51	160025	Wedge Roller (.625 Dia)	2																		
22	160054	Screw: SSS, #10-32 x 0.250 Half Dog Pt.	3	52	160030	Wedge, Narrow	1																		
23	160052	Adjusting Collar Pin	1																						
24	160108	Retainer Ring, Bowed: .394 Dia	1																						
25	141379	Screw: SHCS, #6-32 x .500	1																						
26	160053	Pin: Dowel, .250 Dia. x .500	1																						
27	125070	Quick Disconnect Plug	1																						
28	160093	Internal Gear	1																						
29	160004	External Gear	1																						
30	160085	Center Gear Guard	1																						

162SA
Components
162912: Bracket Assembly- shown here
160911QR: Power Pack Assembly- not shown
141600: Control Valve Assembly-not shown
Serial No. Range
162605-Current

THIS DRAWING IS THE CONFIDENTIAL AND EXCLUSIVE PROPERTY OF C.J. WINTER MACHINE TECHNOLOGIES, INC. AND MAY NOT BE COPIED, REPRODUCED, OR DISCLOSED IN ANY WAY, WHATSOEVER TO ANYONE WITHOUT THE EXPRESS WRITTEN PERMISSION OF C.J. WINTER MACHINE TECHNOLOGIES, INC UNLAWFUL DISCLOSURE MAY RESULT IN PROSECUTION
© 2004 C.J. WINTER MACHINE TECHNOLOGIES, INC.

UNLESS OTHERWISE SPECIFIED: DRAWING MUST COMPLY TO C. J. WINTER ENGINEERING STANDARD E1058 & ASME Y14.5M 1994. UNTOLERANCED DIMENSIONS ARE BASIC
 .020 A B C SW

DRAWN BY: N. Allbornoz
DWG DATE: 2/8/22
ENG. APPR: P. Allart
APPR DATE: 2/8/22
MATERIAL:
HEAT TRT:



162912: Bracket Assmebly

DWG SIZE SCALE: 1:3
B Sheet2
DRAWING NO.
162SA