

REV	ZONE	ECN	REVISION DESCRIPTION	DATE	ENG
F	....	....	Redrawn in Solidworks	2/22	NA

### SECTION B-B

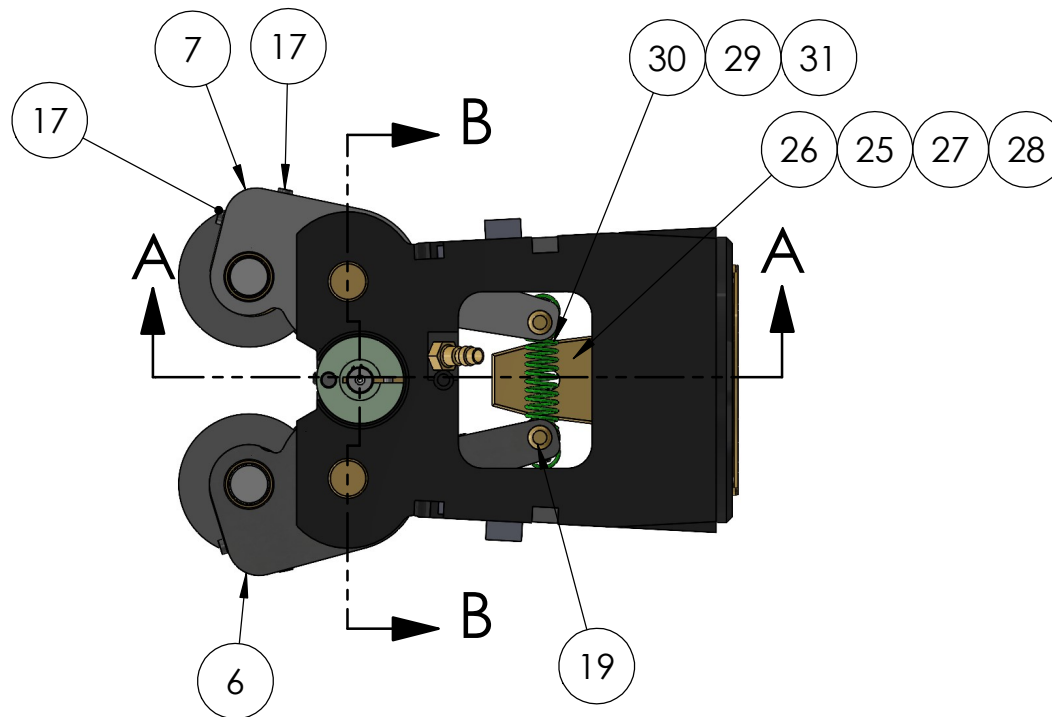

### SECTION A-A

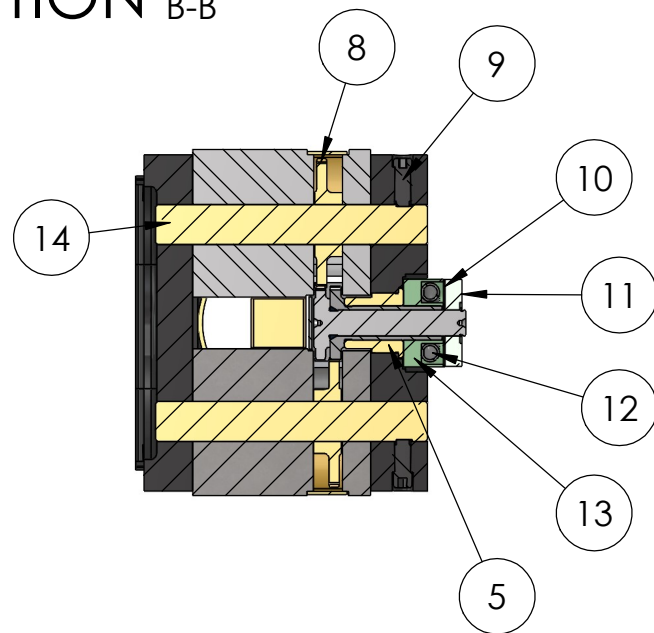
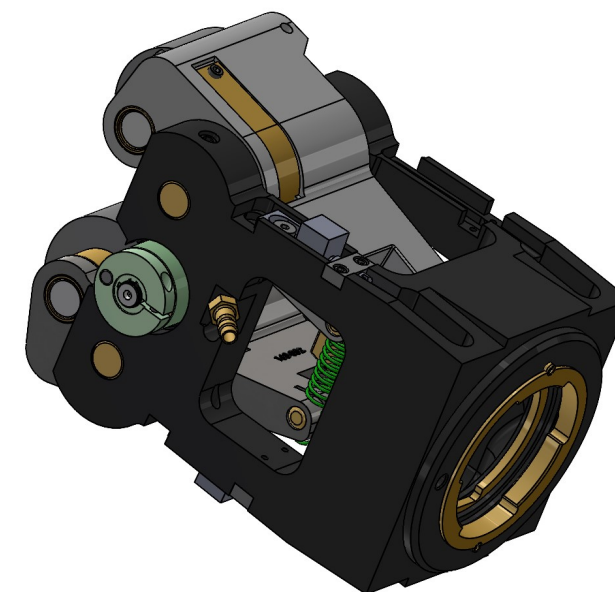
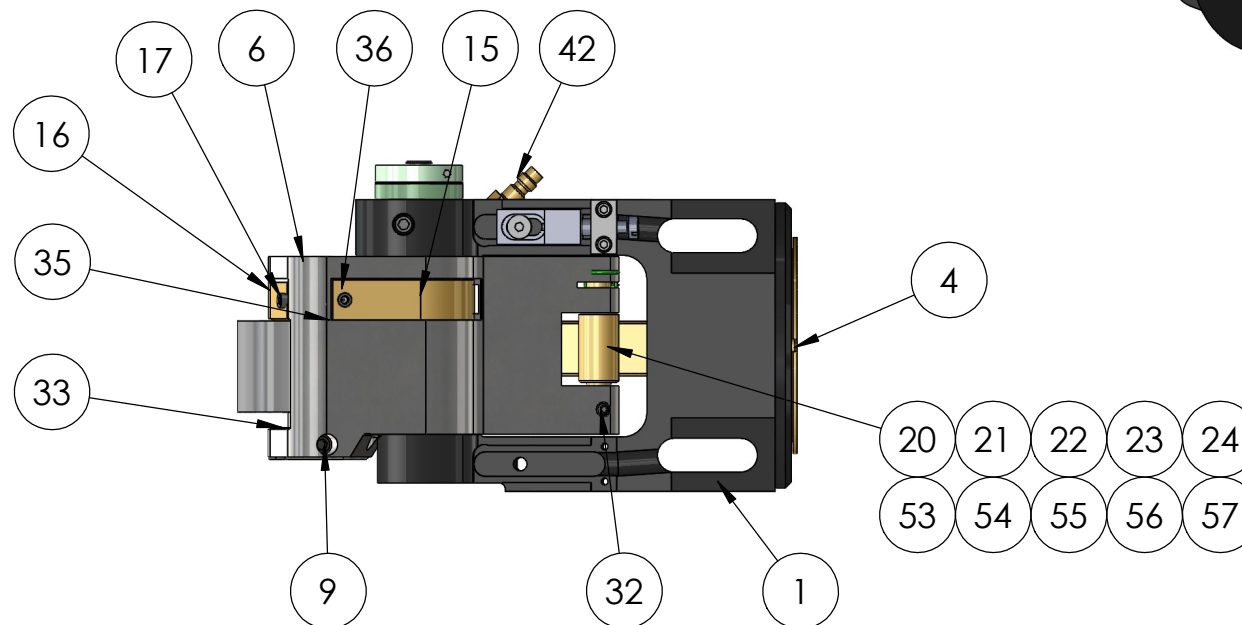
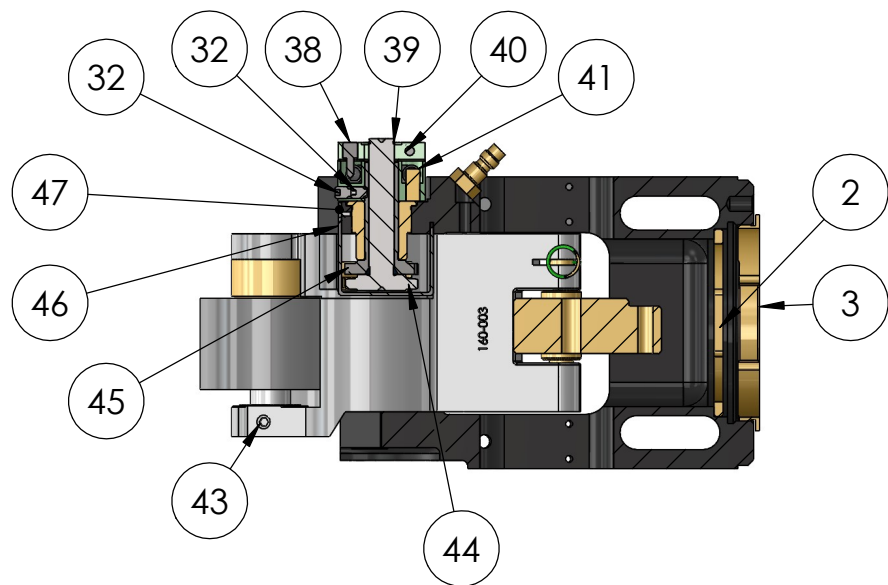

THIS DRAWING IS THE CONFIDENTIAL AND EXCLUSIVE PROPERTY OF C.J. WINTER MACHINE TECHNOLOGIES, INC. AND MAY NOT BE COPIED, REPRODUCED, OR DISCLOSED IN ANY WAY, WHATSOEVER, TO ANYONE WITHOUT THE EXPRESS WRITTEN PERMISSION OF C.J. WINTER MACHINE TECHNOLOGIES, INC. UNLAWFUL DISCLOSURE MAY RESULT IN PROSECUTION © 2004 C.J. WINTER MACHINE TECHNOLOGIES, INC.

UNLESS OTHERWISE SPECIFIED: DRAWING MUST COMPLY TO C. J. WINTER ENGINEERING STANDARD E1058 & ASME Y14.5M 1994. UNTOLERANCED DIMENSIONS ARE BASIC

DRAWN BY: N. Alborno  
 DWG DATE: 2/14/22  
 ENG. APPR: P. Allart  
 APPR DATE: 2/14/22  
 MATERIAL:  
 HEAT TRT:



**C. J. WINTER**  
 MACHINE TECHNOLOGIES, INC.

DWG SIZE SCALE: 1:3  
**B**  
 Sheet1

160914: Bracket Assembly

DRAWING NO.  
**161SA2**

