

Product Bulletin

Heavy Duty Quick Release Roll Arm Brackets

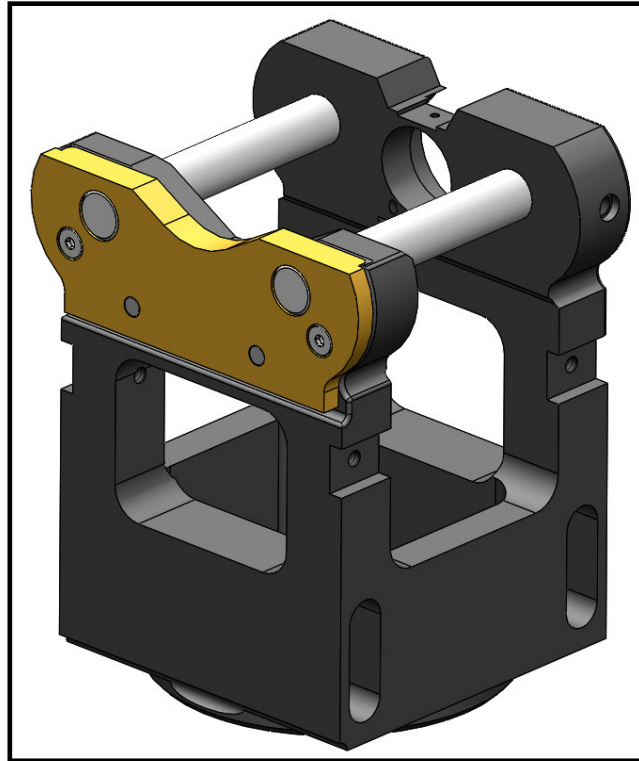

The Heavy Duty Roll Arm Brackets for the 160 and 170 Series attachments are a great way to increase bracket strength and durability for tough rolling applications. The Heavy Duty Roll Arm Brackets are an excellent choice for those looking to roll larger parts and coarser threads with a more rigid and stronger assembly - reducing production issues and increasing attachment life. The transition to a heavy duty bracket almost doubles the thickness of the bracket, making the bracket more rigid when the application requires higher rolling forces. The previous heavy duty brackets featured a design based on thicker sections added with welds, as opposed to the new machined pieces. The new machined assembly was created to ease manufacturing with no loss in strength, and provide more value to the customer. The Heavy duty brackets include longer fulcrum pins, the cover plate, and other hardware necessary to fix the cover plate to the bracket.

CJWinter OEM parts are constantly being redesigned to maximize the value to the Customer. Any parts supplier can sell you yet another replacement part for your problem. Let the team at CJWinter supply you with a cost effective solution to it instead. CJWinter is the World Leader in providing Thread Rolling Solutions ... It's What We Do! Contact your local distributor, or call us directly at 1-800-288-ROLL (7655) and ask about our many new and improved products that will help put profits back where they belong... in your pocket.

Visit us at www.cjwinter.com today to see all of our New Product Bulletins, "How To" videos, technical data and check out our blog page for other helpful information.